

UDK 624.02

O. SLIPYCH, cand. of Tech. Sci., doc., LLC "Industrial Construction Group",
 K. ROMANENKO, cand. of Tech. Sci., doc., D. KRAVTSOVA, cand. of Phys. and Math. Sci.,
 O. BONDAR, cand. of Tech. Sci., doc., Kryvyi Rih National University

INSTALLATION OF A STATIONARY HYDRAULIC HAMMER AT A HEIGHT

Purpose. The article presents a non-standard project for the installation of heavy dynamic equipment at a height - stationary hydraulic hammer.

Research method. It has been illuminated the result of visual and instrumental flaw detection performed by special tools of non-destructive testing and laboratory tests and measurements of constructive elements of a building in which it is necessary to install the hammer. The calculations are made in the software complex "LIRA CAD 2013", which implements the finite element method in displacements.

Scientific novelty. It has been demonstrated the loads calculation on the foundation of the hammer and the plan for its installation at mark of 13,640 meters. It has been analyzed current methods and recent studies of beam reinforcement.

Practical value. After analyzing current methods and recent studies of beam reinforcement, the authors conclude that reinforcement of beams with metal clamps is the most appropriate in this case. First of all, metal can withstand dynamic loads; it does not crumble under tensile forces. Secondly, economic indicators have played a significant role in the selection of the material: the reinforcement project was ordered in the region of iron ore and steel production, so the cost of metal is much lower than the cost of carbon-fiber tapes.

Results. Necessity has been substantiated: (I) strengthening reinforced concrete beams MB52-1 at the mark +13,640 in the axes 4-6 and E-F; (II) installation of steel beams under the foundation of the hammer; (III) installation of shields of the fixed formwork of the hammer foundation. Some recommendations were given.

Key words: install at the height, strengthening reinforced concrete beams, dynamic load, stationary hydraulic hammer.

doi: 10.31721/2306-5451-2021-1-52-64-70

Problem and its connection with scientific and practical tasks. At modern mining enterprises there is a need for additional crushing of large debris of a rock near a crusher when they get stuck in a hopper. For this, stationary hydraulic hammers are used. Its installation at the plant requires careful calculation of the supporting structure due to the large weight of the hammer and its foundation and the presence of dynamic loads. Especially non-standard task is to install it at the height at the operating enterprise.

The purpose of the work is the project of installing a stationary hydraulic hammer ALTA GR-158 at a mark of +13,640 in the building of the large crushing corps of the mining processing plant in the Poltava region of Ukraine. The free space in the building is the unused mounting cavity between the crushers' hoppers. This building is not designed for such equipment. The tasks are: checking existing structures, calculating loads and designing the installation of heavy dynamic equipment at a height that meets the requirements [1-7].

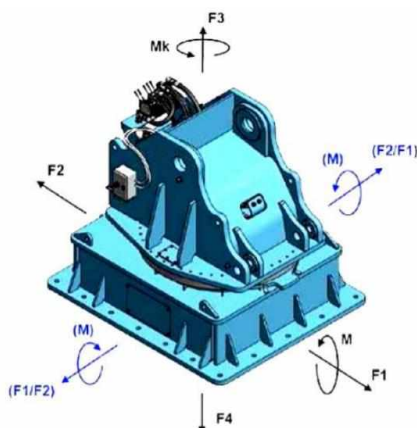

Fig. 1. Scheme of load on the foundation of the hammer GR-158

Methodology and problem statement. The level of the clean surface of the first floor of the building is taken as a mark of 0.000. The building of large crushing corps is a building with a developed underground part with a mark -17,800 to +13,640. The load-bearing elements of the building are reinforced concrete well with monolithic reinforced concrete ceilings, crusher foundations and hoppers. From the mark +13,640 to +38,250 the building is a steel frame enclosed with profiled sheets.

We carried out the construction inspection by methods of computational and analytical diagnostics, which use data from visual and instrumental flaw detection performed by special tools of non-destructive testing and laboratory tests. They allowed determining the physical and mechanical properties of construction materials with a sufficient precision and without destruction. List of works performed during inspection: detection and fixation of visible defects and damage; determination of parameters of the environment of operation; creating a description, sketches and photographs of defective areas; drawing up of schemes and information of defects and

damages; detection of characteristic deformations of buildings (deflections, rolls, bends, distortions, faults, etc.) and emergency areas. In addition, verticality and parallelism of load-bearing elements were checked. In reinforced concrete structures we identified signs of corrosion of reinforcement and embedded parts, the condition of the protective layer, the presence and measurement of cracks.

The main elements that will be considered additional loads are monolithic reinforced concrete beams MB52-1 intersection of 500×1500 mm and monolithic reinforced concrete bunker walls MBSS-1 in the thickness of 1000 mm. At the time of construction inspection, the general state of ceiling at +13.640 in the axes 4-6 and D-G of the building is stable. The state of construction and assemblies, their connections are without changing the geometric characteristics of the constructive scheme. According to the requirements [8], the inspected building structures of the ceiling on the mark +13,640 in axes 4-6 and D-G can be classified as satisfactory. The constructions are in a state of effective condition. Damage and defects affecting the load-bearing capacity are absent.

In most cases, hydraulic hammers are equipment for hydraulic excavators. The principle of operation is the same as a hand-held jackhammer, but the impact energy is more than a thousand times. Most often they are used for loosening of frozen soil, destruction of pavements, crushing of oversized rocks, concrete structures, etc. In crushing factories, the hydraulic hammers are installed stationary above the level of the crushers, but, firstly, these are isolated cases, and secondly, the installation requires individual design.

Table 1

The load on the ceiling at the mark +13,640

Load type	Normative load	Load reliability coefficient γ_f	Dynamic coefficient ϵ	Calculated load
Situation 1 (active rolling stock and inactive hammer)				
Temporary on the railway, kN/r.m.	140	1,3	1,1	200
Temporary on removable shields and free areas of concrete floor, kN/m ²	4	1,2		4,8
Static from the hammer, kN	280	1,2		340
Situation 2 (inactive rolling stock and active hammer)				
Temporary on removable shields and reinforced concrete ceilings, kN/m ²	4	1,2		4,8
Static from the hammer, kN	264	1,2		317
Temporary from the hammer (F1-F4, M, Mk), kN, kN·m	Fig. 1, table 2		2,5	

Table 2

Normative load on the foundation of the hammer GR-158 (F1-Mk - dynamic load, G - static load)

GR 158 (fig. 1)	F1 kN	F2 kN	F3 kN	F4 kN	M kN·m	Mk kN·m	G kN
Max F1	345		149		-424	158	250
Max F2		1189		92	1307	158	250
Max F3	120		456		-438	158	250
Max F4		261		1130	1260	158	250
Max M		1017			1625	158	250
Max -M	283				-548	158	250

A base hammer plate with bolts (2145 kg) is supplied by the manufacturer of hammer ALTA GR-158 (28000 kg).

We took into account the results of diagnostics, hammer characteristics and calculated the MB52-1 beam at the +13,640 mark on the 4-6 and F-E axes, which will handle additional loads. The purpose of the calculations was to determine the stress-strain state of beams from constant and temporary loads, the nature of the distribution of internal forces, the zones of concentration of the greatest stresses. The calculations are made in the software complex "LIRA CAD 2013", which implements the finite element method in displacements. As results table 1 and table 2 show the load on the ceiling on the mark +13,640 without specifying the weight of the structures. It shows that monolithic reinforced concrete beams MB52-1 will not withstand the additional load from the hammer at the mark +13,640 in the axes 4-6 and E-F because the load-bearing capacity of the beams in transverse force is exhausted. In view of all this, to install the stationary hydraulic hammer GR-158 at +13.640, reinforced concrete beams MB52-1 must be strengthened. In addition, installation of shields of the fixed formwork of the hammer foundation is need.

Analysis of research and publications. Today carbon fiber reinforced polymer (CFRP) system is very popular method of reinforcement of beams. Many studies were investigated, which was offered different methods of anchoring the CFRP-reinforcement. The use of steel clamps was found to be the most effective [9-11]. A long-term experiment of work [12] confirms this.

The post-tensioned NSM (near-surface mounted) strengthening system shows good result of effective for improving the crack resistance of concrete structures [13].

However, in previous works, stationary loads were applied to the experimental beams. Dynamic loads are applied in our task and paper [14]. Authors [14] were described that the building was subjected to unidirectional and three-dimensional incremental seismic excitations and dual CFRP/PTMS (Post-Tensioned Metal Straps) retrofitting of columns and joints were effective at restoring the lateral stiffness of the building by 75%.

Composite bonding steel plate (CBSP) is steel structure applicable to the beam bearing high load. According to the methodology of paper [15], the strengthened beam consists of two layers of epoxy bonding pre-stressed steel plates and the beam sandwiched in between. The bonding enclosed and pre-stressed U-shaped steel jackets are applied at the beam sides. As a result the applied plates and jackets jointly behave together with the beam under the action of epoxy bonding and the mechanical anchorage of the steel jackets [15].

Main statement and results. After analyzing current methods and recent studies of beam reinforcement, the authors conclude that reinforcement of beams with metal clamps is the most appropriate in this case. First of all, metal can withstand dynamic loads; it does not crumble under tensile forces. Secondly, economic indicators have played a significant role in the selection of the material: the reinforcement project was ordered in the region of iron ore and steel production, so the cost of metal is much lower than the cost of carbon-fiber tapes.

Fig. 2 shows the scheme for strengthening the design for the installation of the hammer, an oil station and an oil tank between crushers' hoppers. It is also necessary to install additional steel beams that support the foundation of the hammer and panels of fixed formwork – struts (fig. 3).

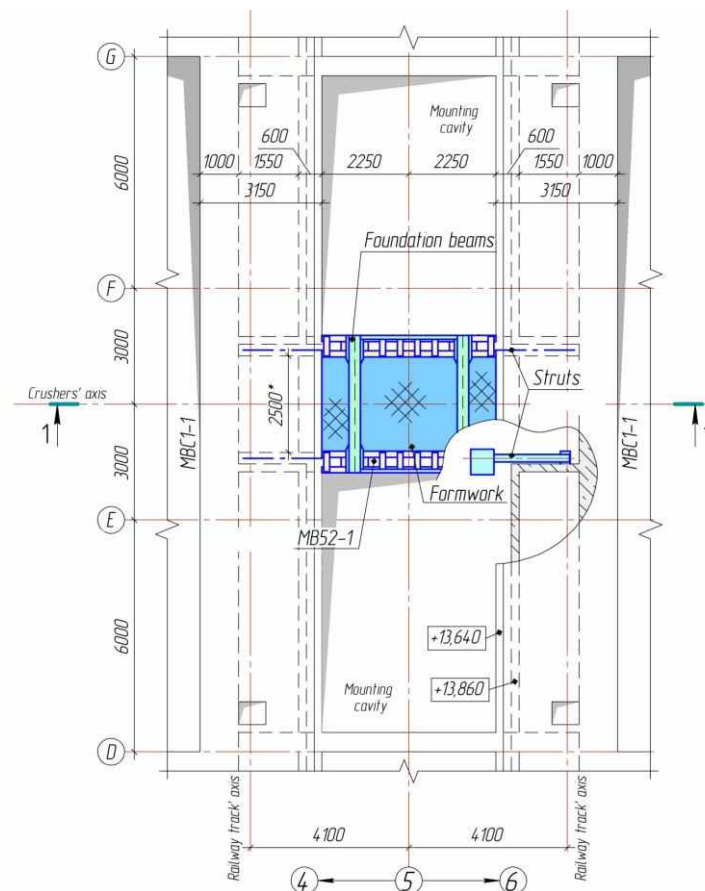

Fig. 2. The scheme of placement of strengthening elements, beams and shields of the formwork of the foundation of the hammer GR-158 at the mark +13,640

Fig. 3. Cross section 1-1 of fig. 2. The scheme of placement of strengthening elements, beams and shields of the formwork of the foundation of the hammer GR-158 at the mark +13,640

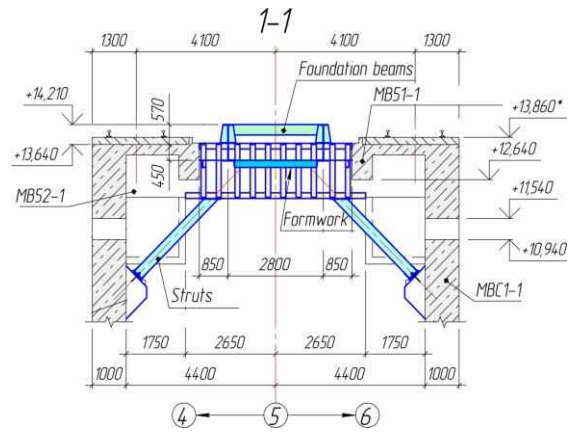

Table 3

Rolled metal products		
Metal products	Designations in the drawing	Total weight, ton
Hot-rolled steel strip metal	-150×14	1.22
Hot-rolled steel sheet metal	-20×240×250	2.01
Hot-rolled steel corner metal	L 160×12	1.3

Fig. 4 shows scheme of installation of the clamps on the beams MB52-1. Different types of rolled metal products are used here (table 3). All structural elements are steel C245, which is analog E235-B (Fe360-B).

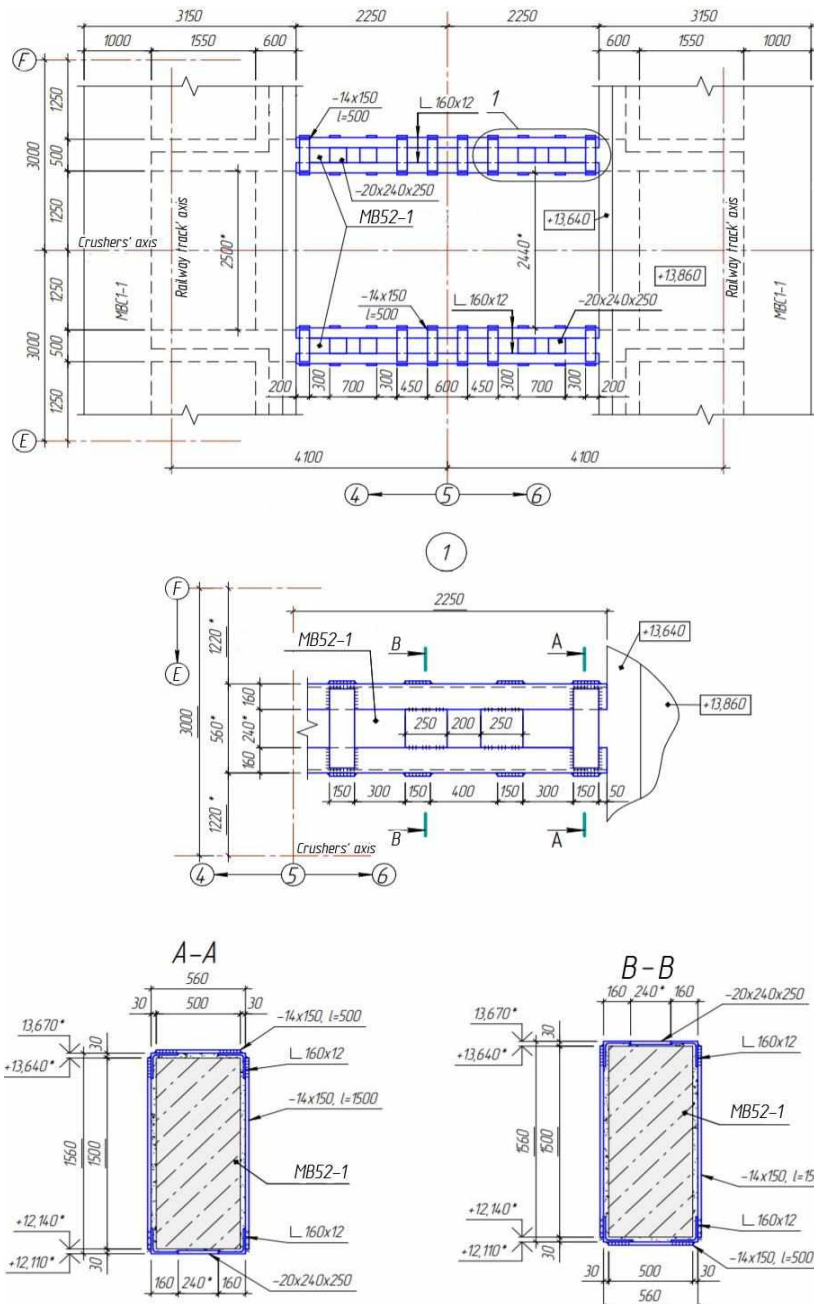

Fig. 4. Scheme of installation of the clamps on the MB52-1 beams

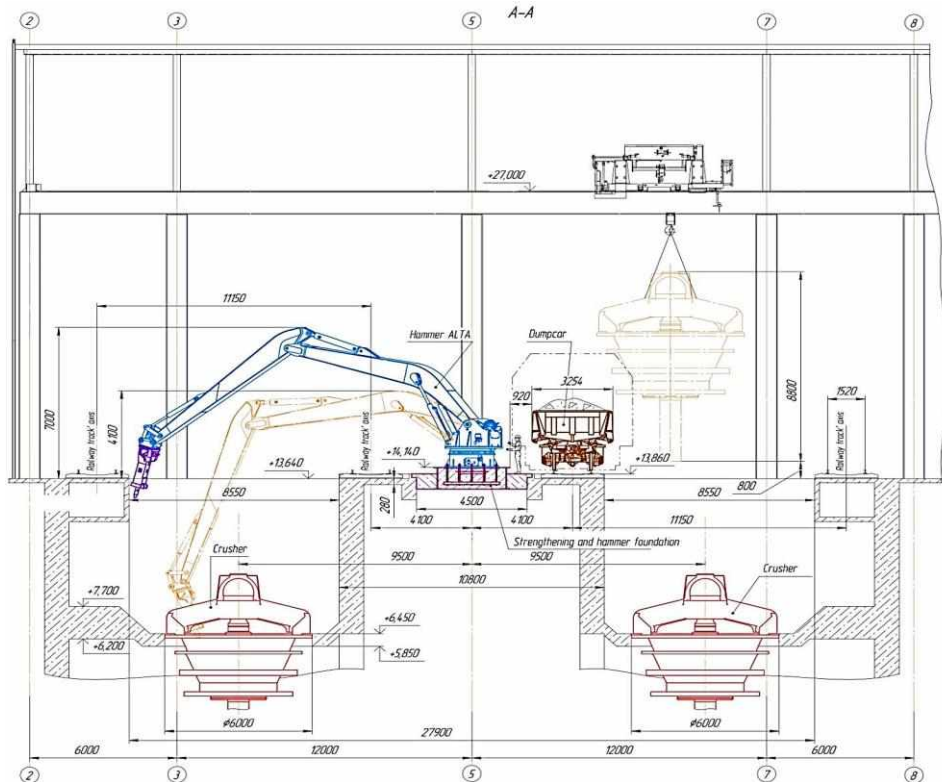

Fig. 6. The plan for the installation of the hammer GR-158 at the mark +13,640. Cross section A-A of fig. 5

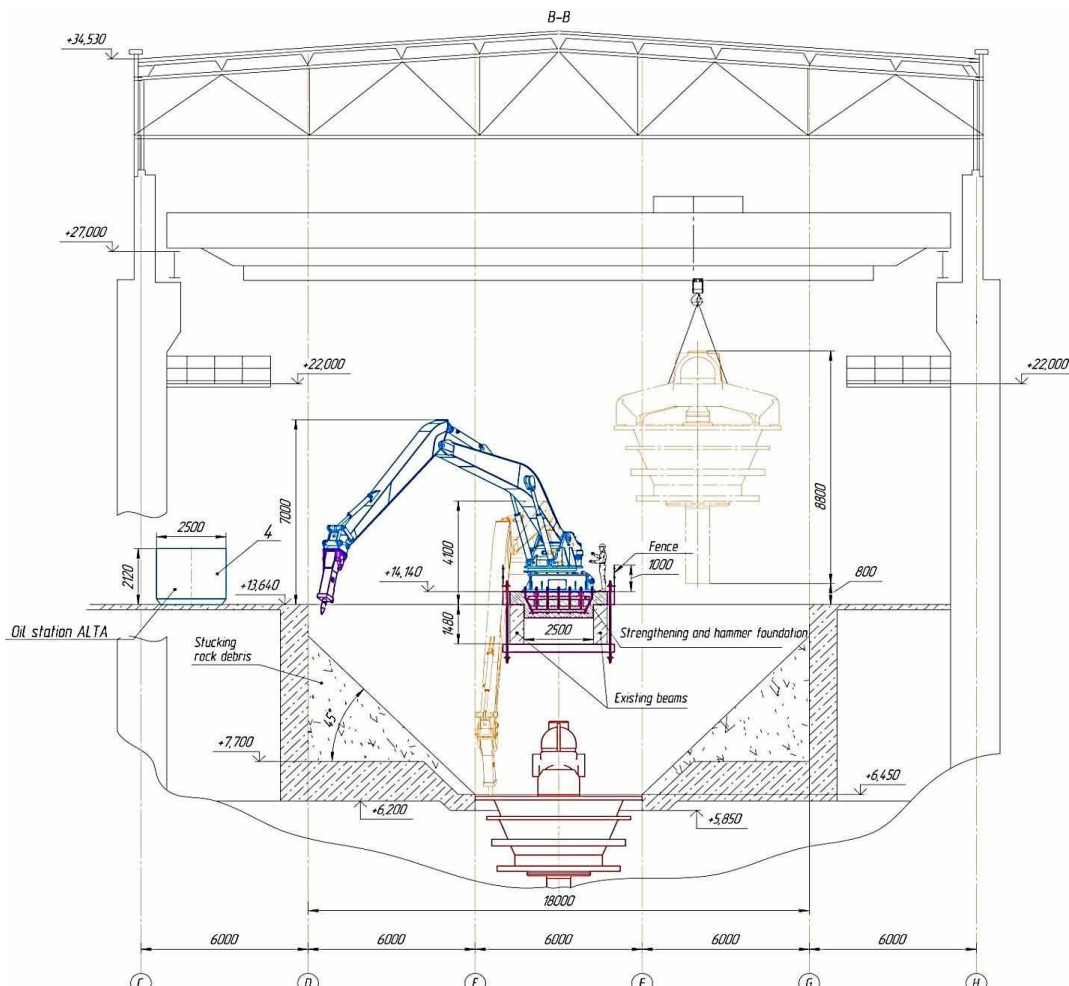

Fig. 7. The plan for the installation of the hammer GR-158 at the mark +13,640. Cross section B-B of fig. 5

Conclusions and future work. It was decided to install stationary hydraulic hammer ALTA GR-158 between the crushers' hoppers in the mounting cavity, which is not used during repair work, at the mark of +13,640 in the building of the large crushing corps of the mining processing plant in the Poltava region of Ukraine.

Necessity has been substantiated: (I) strengthening reinforced concrete beams MB52-1 at the mark +13,640 in the axes 4-6 and E-F; (II) installation of steel beams under the foundation of the hammer; (III) installation of shields of the fixed formwork of the hammer foundation.

The installation project, which ensures the stability of steel structures at all stages of work, must be developed in advance. After installation the entrance of railway transport to neighboring hammer railways is prohibited during the operation of the hammer.

References

1. **Turkstra C.J.** Theory of Structural Design Decisions, SM Studies Series No. 2. Ontario, Canada: Solid Mechanics Division, University of Waterloo. 1970.
2. Eurocode - Basis of structural design : EN 1990:2002+A1. - Brussels : Management Centre, 2002. - 116 c. - (European Standard).
3. Eurocode 2: Design of concrete structures - Part 1-1: EN 1992-1-1:2004.- Brussels: Management Centre, 2008. - 225 c. - (European Standard).
4. EN 1991-1-3. Eurocode 1 – Actions on structures. Part 3: Actions induced by cranes and machinery – Brussels: CEN, 2003. – 43 P.
5. Eurocode 3: Design of steel structures – Part 4-1: Silos : EN 1993-4-1. – Brussels : Management Centre, 2007. – 114 c. – (European Standard).
6. **Barashikov A.Y., Malyshev O.M.** Estimation of technical condition of building structures, buildings and structures. - K.: NMC Derznaglyadodohoronpraci Ukrainy, 1998. - 23 p.
7. DBN V.3.1-1-2002. Repair and strengthening of bearing and enclosing building constructions and bases of industrial buildings and constructions.. State Committee on Construction and Architecture of Ukraine. Kiev. 2003 - 82 pp. - (State building codes of Ukraine).
8. **Gulvanessian H. and Holicky M.** Eurocodes: Using Reliability Analysis to Combine Action Effects. Proceedings of the Institution of Civil Engineers Structures & Buildings. August 2005, vol. 158, no. SB4, pp. 243—252.
9. **Skuturna, T., & Valivonis, J.** (2016). Experimental study on the effect of anchorage systems on RC beams strengthened using FRP. Composites Part B: Engineering, 91, 283-290. <https://doi.org/10.1016/j.compositesb.2016.02.001>
10. **Demir, A., Ercan, E., & Demir, D. D.** (2018). Strengthening of reinforced concrete beams using external steel members. Steel and Composite Structures, 27(4), 453-464.) DOI: <https://doi.org/10.12989/scs.2018.27.4.453>
11. **Helal, Y., Garcia, R., Pilakoutas, K., Guadagnini, M., & Hajirasouliha, I.** (2016). Strengthening of short splices in RC beams using post-tensioned metal straps. Materials and Structures, 49(1-2), 133-147. DOI 10.1617/s11527-014-0481-6
12. **Jin, F., & Lees, J. M.** (2019). Experimental Behavior of CFRP Strap–Strengthened RC Beams Subjected to Sustained Loads. Journal of Composites for Construction, 23(3), 04019012. [https://doi.org/10.1061/\(ASCE\)CC.1943-5614.0000936](https://doi.org/10.1061/(ASCE)CC.1943-5614.0000936)
13. **Lee, H. Y., Jung, W. T., & Chung, W.** (2017). Flexural strengthening of reinforced concrete beams with pre-stressed near surface mounted CFRP systems. Composite Structures, 163, 1-12. <https://doi.org/10.1016/j.compstruct.2016.12.044>
14. **Garcia, R., Pilakoutas, K., Hajirasouliha, I., Guadagnini, M., Kyriakides, N., & Ciupala, M. A.** (2017). Seismic retrofitting of RC buildings using CFRP and post-tensioned metal straps: shake table tests. Bulletin of Earthquake Engineering, 15(8), 3321-3347. <http://dx.doi.org/10.1007/s10518-015-9800-8>
15. **Yang, S. H., Cao, S. Y., & Gu, R. N.** (2015). New technique for strengthening reinforced concrete beams with composite bonding steel plates. Steel and Composite Structures, 19(3), 735-757. <https://doi.org/10.12989/scs.2015.19.3.735>

УДК 621.311.1

I. О. СІНЧУК, С. М. БОЙКО, І. В. КАСАТКІНА, кандидати техн. наук, доценти,
О. В. ДОЗОРЕНКО, асп., Криворізький національний університет

АСПЕКТИ РОЗВИТКУ ВІТРОЕНЕРГЕТИКИ В УМОВАХ ЗАЛІЗОРУДНИХ ПІДПРИЄМСТВ

Мета. Метою даної роботи є розробка тактики визначення вітрового потенціалу в умовах залізорудних підприємств з подальшим втіленням цього підходу до впровадження вітроенергетичних установок, як джерел автономного живлення в структурах систем електропостачання цих видів підприємств.